



GASTON GT

range is the most common standard and the first generation delicate product which is designed with AGM(Absorbent Glass Mat) technology, high performance plates and electrolyte. The definition of GT is coming from General purpose. Therefore, this range product has possessed various applications for common power backup system.

Applications

- | | |
|---------------------------|--|
| Alarm System | Medical Equipment |
| Cable Television | UPS |
| Communication Equipment | Power Tool |
| Control Equipment | Emergency Power System |
| Security System | Stand-by Electric Power Control System |
| Emergency Lighting System | |

General Features

- Sealed and maintenance free operation.
- Non-Spillable construction design.
- ABS containers and covers(UL94HB, UL94V-0) optional.
- Safety valve installation for explosion proof.
- High quality and high reliability.
- Exceptional deep discharge recovery performance.
- Low self discharge characteristic.
- Flexibility design for multiple install positions.

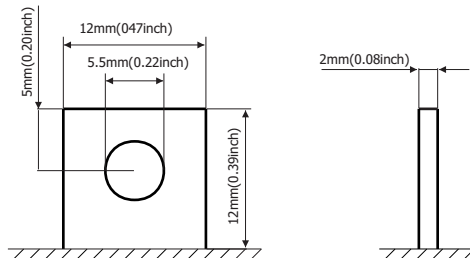

Standard Terminal Dimensions
(Optional terminal please check terminal information page)

Construction

- | | | | |
|-----------|-------------------|--------------|--------------------|
| Component |Raw material | Sealant |Epoxy Resin |
| Positive |Lead dioxide | Safety valve |EPDR |
| Negative |Lead | Terminal |Copper |
| Container |ABS | Separator |Fiber glass |
| Cover |ABS | Electrolyte |Sulfuric acid |

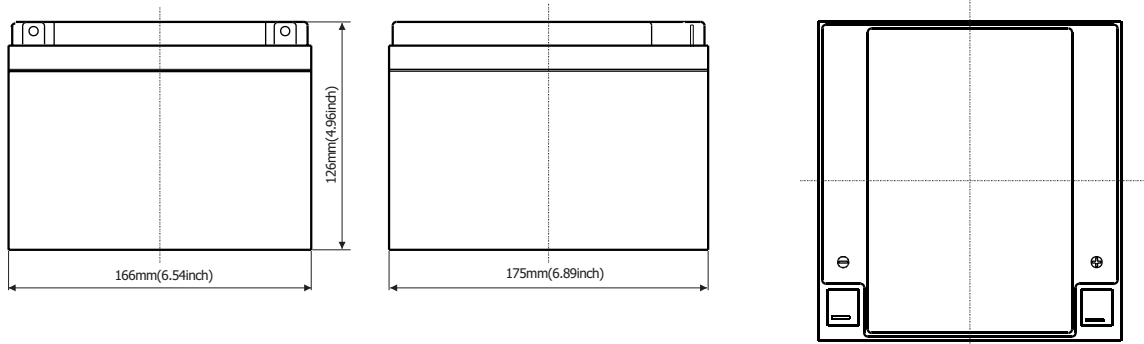

Battery Model	GT 12-26			
Designed Floating Life	8 Years			
Capacity(25°C)	20HR(1.3A,1.75V)	10HR(2.5A,1.75V)	5HR(4.42A,1.75V)	1HR(15.7A,1.75V)
	26Ah	25Ah	22.1Ah	15.7Ah
Dimensions	Length	Width	Height	Total Height
	166mm(6.54inch)	175mm(6.89inch)	126mm(4.96inch)	126mm(4.96inch)
Approx. Weight	8.9Kg (19.62 lbs)			
Internal Resistance	Full charged at 25°C: 0.01 Ohm			
Self Discharge	3% of capacity declined per month at (25°C)			
Capacity Affected by Temp.(20HR)	40°C	25°C	0°C	-15°C
	102%	100%	85%	65%
Charge Voltage(25°C)	Cycle use		Float use	
	14.4-15V(-30mV/ °C), max. Current: 6.5A		13.6-13.8V(-20mV/ °C)	

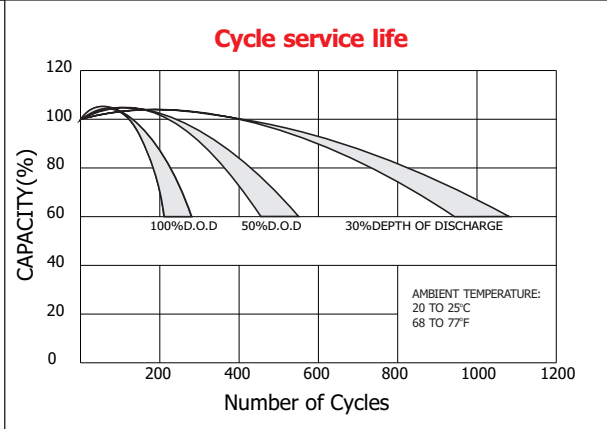
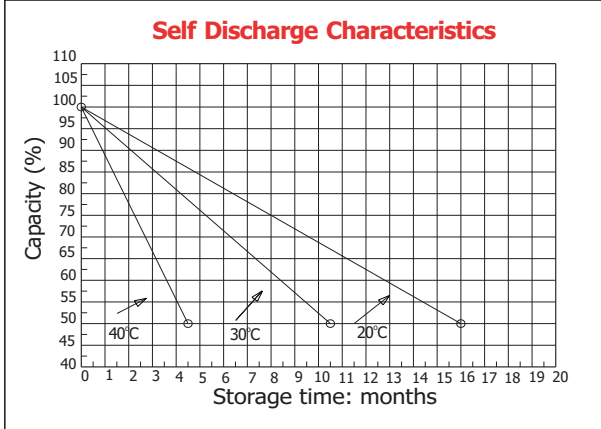
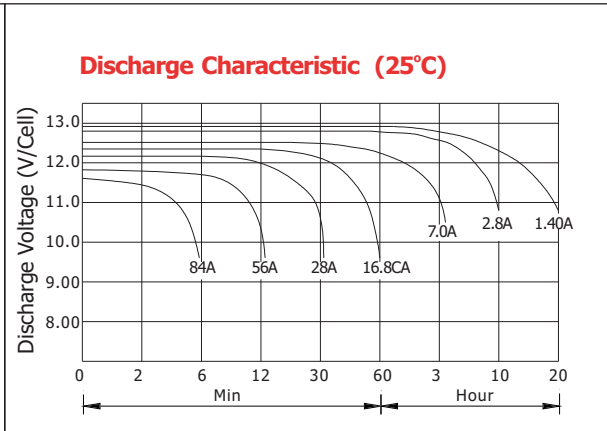
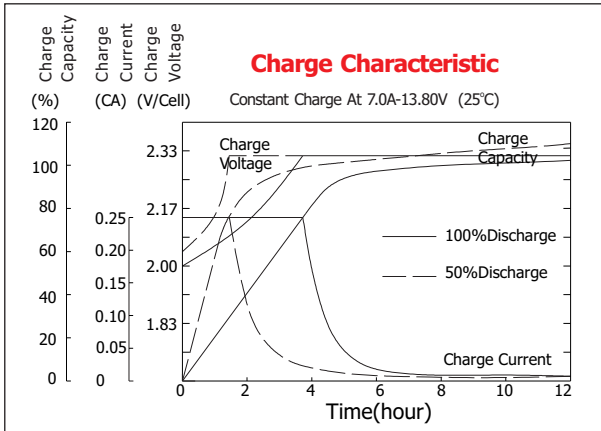

Constant current discharge ratings-amperes at 25°C

F.V/Time	5MIN	10MIN	15MIN	30MIN	1HR	3HR	5HR	10HR	20HR
1.60V	91.0	62.4	45.5	27.3	17.2	7.10	4.96	2.76	1.37
1.67V	81.9	56.9	44.2	26.5	17.1	7.07	4.92	2.72	1.37
1.70V	77.7	54.9	42.6	26.0	17.1	7.07	4.92	2.69	1.37
1.75V	69.2	50.7	40.3	25.5	16.9	7.02	4.88	2.65	1.36
1.80V	62.4	47.1	38.5	24.7	16.7	6.99	4.84	2.60	1.31
1.85V	47.3	38.7	33.3	22.7	16.5	6.97	4.80	2.56	1.23

Constant power discharge ratings-watts at 25°C

F.V/Time	5MIN	10MIN	15MIN	30MIN	1HR	3HR	5HR	10HR	20HR
1.60V	150	103	80.6	51.5	33.8	13.6	9.49	5.51	2.74
1.67V	142	102	79.8	50.4	32.7	13.6	9.49	5.43	2.73
1.70V	133	100	78.5	49.1	31.8	13.6	9.49	5.39	2.73
1.75V	124	93.1	73.8	47.8	31.5	13.4	9.39	5.30	2.72
1.80V	111	86.6	69.4	46.5	31.0	13.2	9.23	5.20	2.62
1.85V	88.9	71.8	60.6	42.6	30.7	13.2	9.10	5.11	2.46

